

Automated Orthogonal ESI Control System with Optimized Plume-Inlet Positioning

Mike S. Lee¹, Gary A. Valaskovic²

¹ Milestone Development Services, Newtown, PA ² New Objective, Inc., Woburn, MA

Introduction

Nanospray is an empowering technology for qualitative analysis. However, relatively poor reproducibility can limit quantitative application. As reported in recent literature, variations in spray morphology affect spectral quality and data. A PC vision-based self-tuning source for use with gradient chromatography was developed to automatically control spray mode (Valaskovic, et al., *JASMS*, 2004, 15, 1201). Here we report the extension of this method to optimize spray position (U.S. Patent 6,744,046). Vision-based feedback control maintains spray in an optimized position relative to the spectrometer inlet. Figures of merit, including repeatability and standard deviation for repetitive flow injection analysis of a small molecule drug, are discussed in this investigation. The system was tested in two modes: (1) Continuous infusion nanospray and (2) Flow injection nanospray.

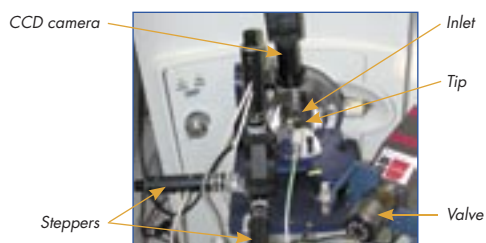

Methods & Materials

Instrumentation and Components

- Ion trap mass spectrometer (LCQ Deca™, Thermo Electron) fitted with custom capillary extension tube
- Nanospray Source (modified PicoView® 500, New Objective)
- Upchurch 10-port NanoPeak™ valve with a 0.8 µL loop, connected to a SilicaTip™ emitter (360 µm OD x 20 µm ID x 10 µm tip with distal coating, New Objective)
- XYZ Stage equipped with stepper motor control

Mobile Phase Delivery (50% Acetonitrile (ACN), 0.1% formic acid)

- A 1 µM solution of buspirone (Aldrich Chemical)
- Continuous flow rates of 150 nL/min. and 400 nL/min. delivered via syringe pump fitted with a 250 µL syringe
- NanoLC™ pump (Eksigent Technologies)

Sample

- Buspirone (Aldrich Chemical) 1 µM solution, 50% ACN, 0.1% formic acid

Software & Operation

A reference library of spray images is used to locate the spray position within the field of view. The feedback control system subsequently maintains the spray plume in a given reference position, regardless of emitter size, length, or angle.

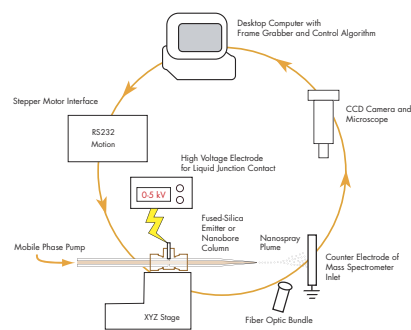

Figure 1 Diagram of the feedback system

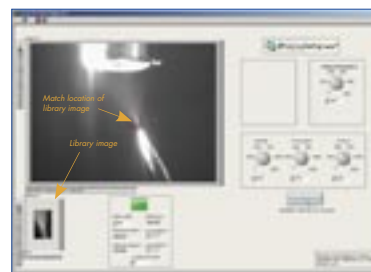

Figure 2A Step 1 - Spray voltage and emitter XYZ position are manually adjusted through the user interface. A library spray image is used to locate the feedback reference position.

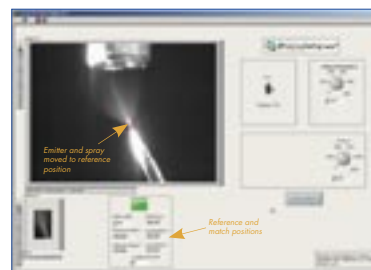

Figure 2B Step 2 - The emitter position is automatically adjusted to maintain the spray plume at the reference position.

Results

Intra-Emitter Performance

Inter-Emitter Performance

Continuous Infusion - Syringe Pump

Flow rate = 400 nL/min.

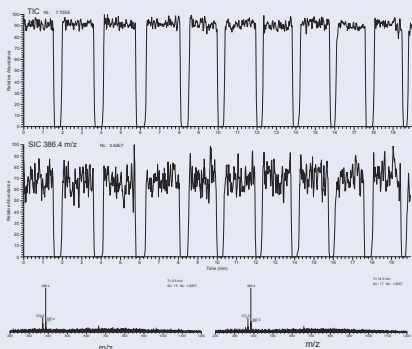

System auto-location performance After each 1.5 min. interval, the emitter was retracted and manually placed in a random new position. Upon re-start, the system restored the spray to the reference position. See quantitative data in Tables 1 & 2.

Flow rate = 150 nL/min.

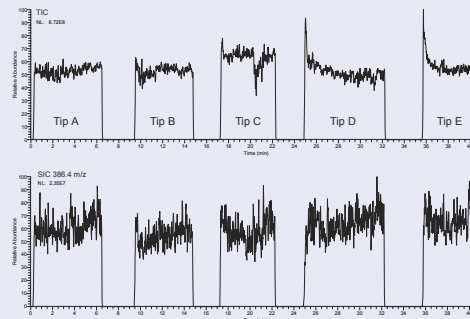

Performance with five different 10 μm emitters The system was placed into standby mode. A new emitter was mounted, with emitter length and position intentionally varied by 1 mm or more. Note the TIC and SIC returned to a normalized level after a brief rinse-out.

Flow Injection Nanospray - NanoLC™ Pump

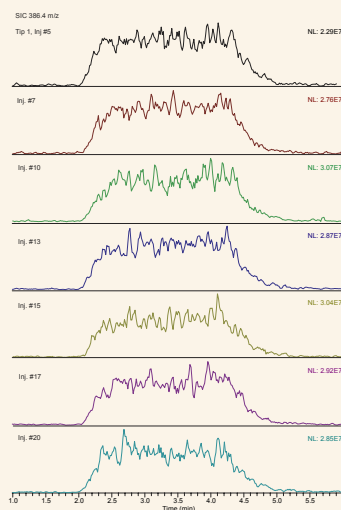

Selected Ion Current (SIC) injection profiles for a 0.8 μL sample of 1 μM buspirone pumped at 400 nL/min. through the same 10 μm emitter. The emitter was retracted, manually re-positioned at random, and auto-tuned between each injection. See quantitative information in Tables 1 & 2.

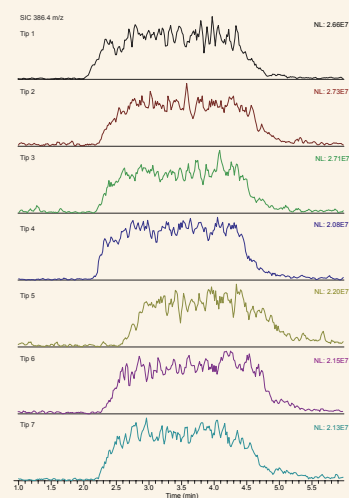

Selected Ion Current (SIC) injection profiles for a 0.8 μL sample of 1 μM buspirone pumped at 400 nL/min. through seven different emitters. The system auto-tuned position after each new emitter was mounted. See quantitative information in Tables 1 & 2.

Results

Data Analysis

Continuous Infusion Nanospray

Table 1

PEAK LIST		RT: 0.00 - 19.98		Number of detected peaks: 9			
Apex RT	Start RT	End RT	Area	%Area	Height	%Height	
2.09	1.89	3.71	175885327	11.23	22731453.3	10.29	
5.71	4.02	5.84	1753128826	11.2	26382045.3	11.94	
7.46	6.18	8.16	1911898511	12.21	22375253.3	10.12	
9.65	8.43	10.12	1607721220	10.27	25980461.3	11.76	
11.83	10.19	12.07	1777752279	11.35	24945746.7	11.29	
12.42	12.18	13.98	1721743541	11	24623533.3	11.14	
14.32	14.11	15.89	1734084010	11.07	24039550.7	10.88	
17.15	15.99	17.73	1676399659	10.71	23877717.3	10.8	
19.09	17.86	19.64	1717100210	10.97	26038792	11.78	
			Ave	1739852820	24554512.6		
			STD	8211218	1437819		
			% STD	4.7%	6%		

Flow Injection Nanospray

Table 2

Tip#	Number of Injection (n)	Average	STD	% STD
1	15	2699408384	149083997	5.5%
2	5	2427865517	84122849	3.5%
3	5	2374849474	51951478	2.2%
4	6	2332955612	97663016	4.2%
5*	1	2094020298	NA	NA
6	5	2446366679	126168841	5.2%
7	5	2094073768	127643495	6.1%

* Tip clogged after 1 injection, removed from average data ensemble

Intra-Tip Average (15 inj.): 2.69E9	Inter-Tip Average (41 inj., 6 tips): 2.46E9
Intra-Tip STD: 1.49E8	Inter-Tip STD: 2.38E8
Intra-Tip % STD: 5.5%	Inter-Tip % STD: 9.5%

Conclusions

- Library-based pattern matching determines the precise spray plume location within <5 μm (2 pixels) at flow rates of 50 nL/min. or less
- High-precision plume location allows feedback control of plume position with respect to an established reference position
- High reproducibility of plume positioning permits standard deviation of SIC flow injection analysis from a single emitter to be better than 5%; this value is essentially equivalent to the short term stability of the instrument
- Reproducibility extends to emitter replacement and minor changes in plumbing volume (including varying emitter lengths), yielding an inter-emitter standard deviation of better than 10%
- Future experiments will include the integration of a spray mode control algorithm and an auto-focusing routine for control of the probe-height axis

Acknowledgements

The authors would like to acknowledge Dr. Jim Stephenson of RTI International for helpful discussions on feedback-controlled electrospray, as well as Eksigent Technologies for the use of their NanoLC™ pump.